

CALL 1-800-577-8111 FOR SALES AND SUPPORT

Blue-White[®]

Industries, Ltd.

DIAPHRAGM INJECTOR
MODEL C-600P & C-600HV

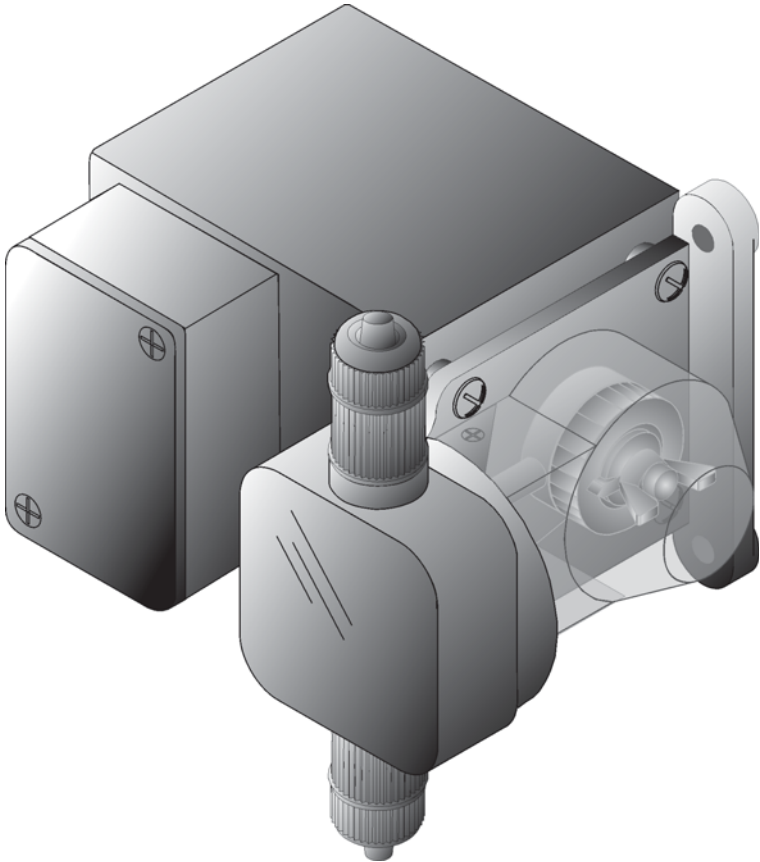

3.0 Features

- Double-ball ceramic check valves.
- PVDF (Kynar) valve assemblies.
- Viton o-rings.
- High outlet pressure capability of 125 PSIG.*
- Easy access, side mounted mechanical feed rate adjustment.
- Ball bearing supported motor drive shaft.
- Permanently lubricated ball bearing motor.
- 27:1 adjustment turn down ratio.
- Easy servicing.
- Includes suction tube foot valve & strainer, suction tube weight, suction tubing, discharge tubing and injection fitting with internal back-flow check valve and mounting hardware.

* Most C-600P Models. C-600HV has max pressure rating of 20 PSIG

4.0 How To Install the Metering Pump

CAUTION: PROPER EYE AND SKIN PROTECTION MUST BE WORN WHEN INSTALLING AND SERVICING THE PUMP

CAUTION - This pump has been evaluated for use with water only.

Note: All diagrams are strictly for guideline purposes only. Always consult an expert before installing the metering pump into specialized systems.

The metering pump should be **serviced by qualified persons only.**

4.1 Mounting Location

Choose an area located near the chemical supply tank, chemical injection point and electrical supply. Install the pump where it can be easily serviced.

- Mount the pump to a secure surface or wall using the enclosed hardware. Wall mount to a solid surface only. Mounting to drywall with anchors is not recommended.
- Keep the outlet (discharge) tubing as short as possible. Longer tubing increases the back pressure at the pump head.
- Do not mount the pump directly over your chemical container. Chemical fumes may damage the unit. Mount the pump off to the side or at a lower level than the chemical container.
- Mounting the pump lower than the chemical container will gravity feed the chemical into the pump. This “flooded suction” installation can reduce the time required to prime the pump. Install a shut-off valve, pinch clamp or other means to halt the gravity feed to the pump during servicing.
- Your solution tank should be sturdy. Keep the tank covered to reduce fumes.
- Be sure your installation does not constitute a cross connection with the drinking water supply. Check your local plumbing codes.

C-600P

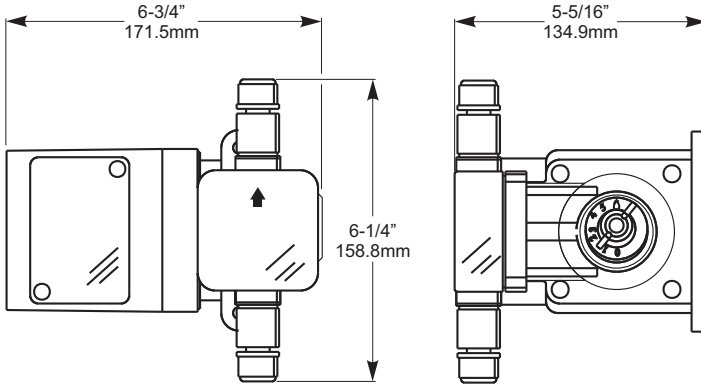

C-600HV

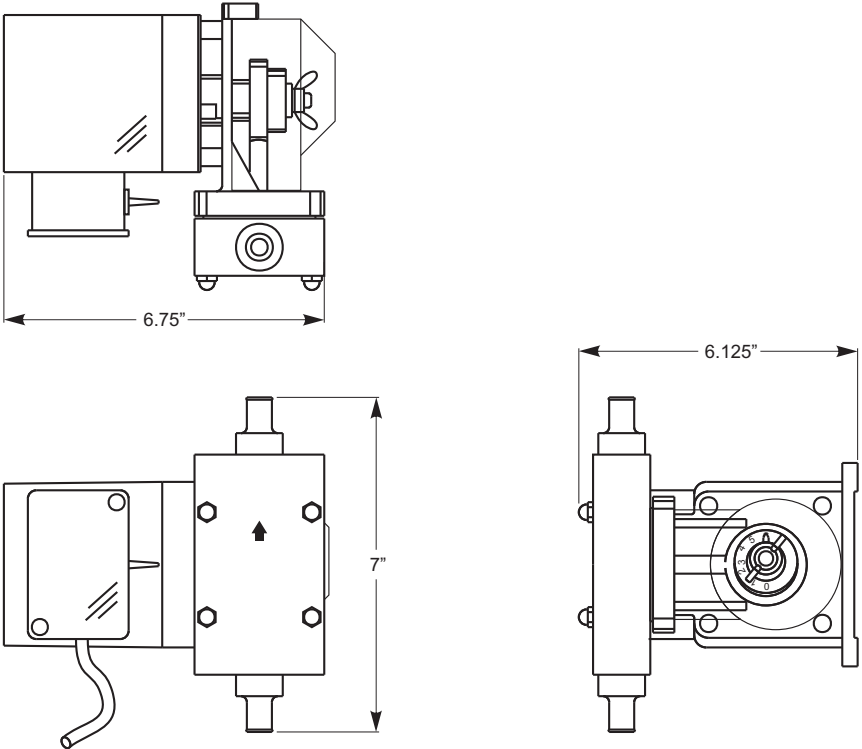
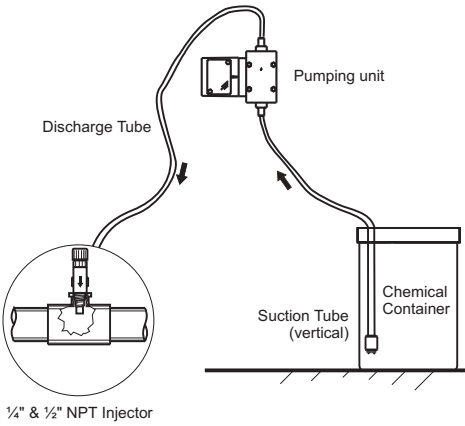
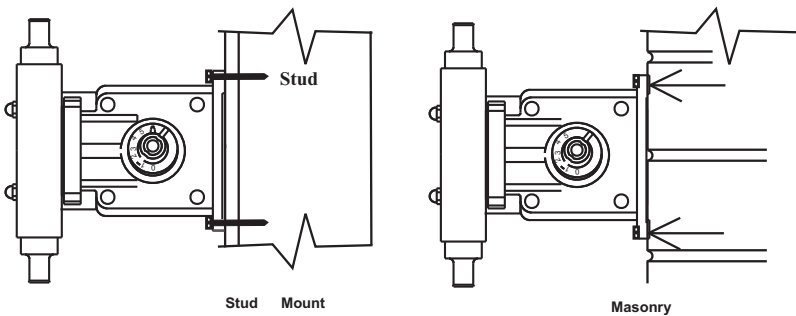

FIG. 4.1 DIMENSIONAL DRAWING



TYPICAL INSTALLATION



WALL MOUNTING

4.2 Electrical Connections

Be certain to connect the pump to the proper supply voltage. Using the incorrect voltage will damage the pump and may result in injury. The voltage requirement is printed on the pump serial label.

Note: When in doubt regarding your electrical installation, contact a licensed electrician.

The metering pump is supplied with a junction box for field wiring.

JUNCTION BOX MODELS -To reduce the risk of electric shock, be certain that a grounding conductor is connected to the green grounding screw located in the junction box.

WARNING -RISK OF ELECTRICAL SHOCK

MOTOR LEADWIRES

INPUT VOLTAGE	HOT LEADWIRE	NEUTRAL LEADWIRE	GROUND LEADWIRE
115V 60Hz	BLACK or YELLOW*	BLUE	GREEN
220V 50Hz	BLUE or YELLOW*	BROWN	GREEN
230V 60Hz	BLACK or YELLOW*	RED	GREEN
24V 60Hz	BLUE*	WHITE	GREEN

* Yellow leadwire : thermally protected motor
 Black or Blue leadwire: standard impedance protected motor

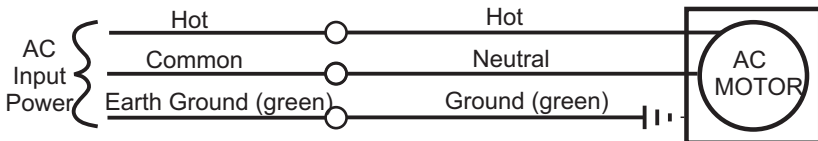

FIG. 4.5 WIRING DIAGRAM - STANDARD MODELS

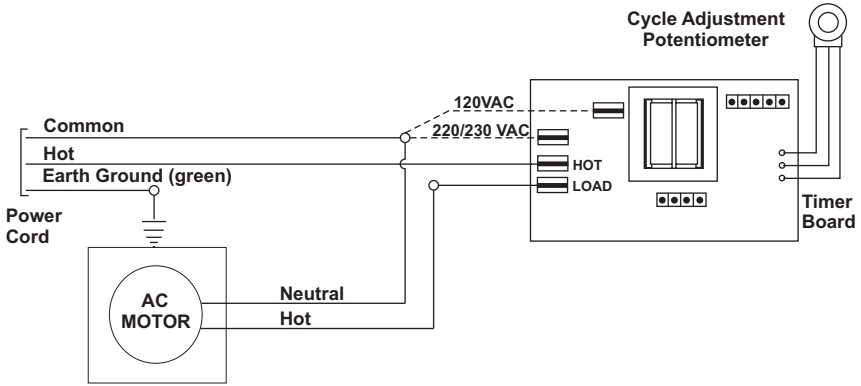

FIG. 4.6 WIRING DIAGRAM - FIXED TIMERS

4.3 How To Install the Tubing and Fittings

CAUTION: PROPER EYE AND SKIN PROTECTION MUST BE WORN WHEN INSTALLING AND SERVICING THE PUMP

Inlet Tubing - Locate the inlet fitting of the pump head. Remove the tube nut. Push the clear PVC suction tubing onto the compression barb of the fitting. Use the tube nut to secure the tube. Hand tighten only.

Footvalve/Strainer -Trim the inlet end of the suction tubing so that the strainer will rest in a vertical position, approximately one inch from the bottom of the solution tank. This will prevent sediment from clogging the strainer. Loss of prime may occur if the footvalve is permitted to lay on the bottom of the solution tank in a horizontal position. Slip the ceramic weight over the end of the suction tube. Press the footvalve/strainer into the end of the tube. Secure the ceramic weight to the strainer. Drop the strainer into the solution tank.

Outlet Tubing - Locate the outlet fitting of the pump head, Remove the tube nut. Push the rigid outlet (discharge) tubing onto the compression barb of the fitting. Use the tube nut to secure the tube. Hand tighten only.

Trim the other end of the outlet tube leaving only enough slack to connect it to the Injection/Check valve Fitting . Increasing the length of the outlet tube increases the back pressure at the pump head, particularly when pumping viscous fluids.

Keep the inlet and outlet tubes as short as possible.

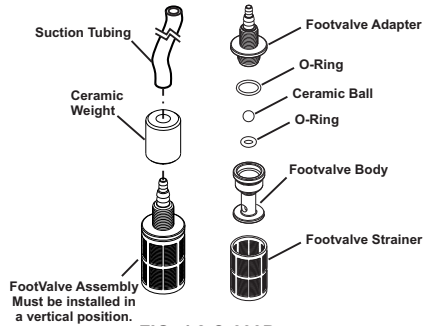
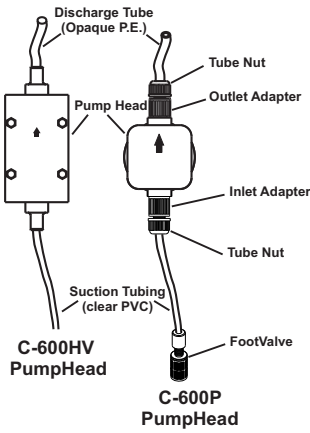

FIG. 4.8 C-600P FootValve Assy.

4.3.4 Injection/Check Valve Fitting Installation - The Injection/Check valve fitting is designed to install directly into either 1/4" or 1/2" female pipe threads. This fitting will require periodic cleaning, especially when injecting fluids that calcify such as sodium hypochlorite. These lime deposits and other build ups can clog the fitting increasing the back pressure and interfering with the check valve operation.

Install the Injection/Check valve directly into the tee fitting. Do not install the fitting into a pipe stud and then into the tee. The solution must inject directly into the flow stream.

Use Teflon thread sealing tape on the pipe threads. Push the opaque outlet (discharge) tubing onto the compression barb of the Injection/Check valve fitting. Use the tube nut to secure the tube. Hand tighten only.

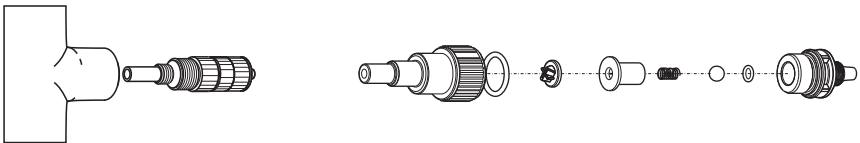
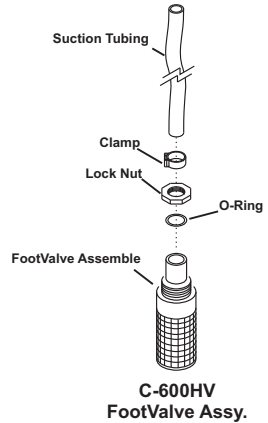

FIG. 4.9 C-600P INJECTION/CHECK VALVE TEE INSTALLATION AND EXPLODED VIEW

5.0 How To Operate The Pump

5.1 Adjusting the Pump Output- The flow rate can be adjusted within a range of approximately 10%-100% of maximum output (27:1 turndown ratio) by means of a mechanical, cam type mechanism. The mechanism adjusts the pump's stroke length to 1 of 27 settings within the flow range. The pump's output is affected by the pressure of the system, the amount of suction lift, and the viscosity of the fluid being injected into the pump must be over-sized to allow for these factors. Sizing the pump to allow adjustment within the midrange is preferred to maintain accuracy. Consult the factory for individual pump model output curve data.

To adjust the pump output:

1. Make sure the pump is off before adjusting.
2. Loosen the wing nut.
3. Turn adjusting knob so the pointer is on the desired setting. *Note:* pump less chemical at first, then re-adjust.
4. While holding the knob, tighten the wing nut to keep the knob at the desired setting. *Note:* wing nut must be tight.

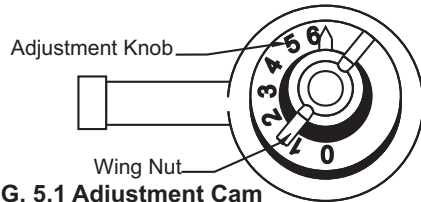

FIG. 5.1 Adjustment Cam

Priming The Pump

Each pump is factory tested with water. The test water is sealed in the pump head keeping the valves dry to aid in priming. If the valves have dried or priming is difficult due to back pressure, do the following:

1. Remove the opaque discharge tubing from the top valve fitting in the pumphead.
2. Remove the top and bottom valve fittings and immerse in water to wet the valves. Reinstall the fittings.
3. With the discharge tubing removed, start the pump. Stop the pump when the fluid enters the pumphead.
4. Attach the discharge tubing to the top valve fitting.
5. Be sure the footvalve/strainer is attached to the suction tubing and is installed in a vertical position.

If your installation is at high altitude, priming may be more difficult since the atmospheric pressure is decreased. When the suction line is dry, the diaphragm may not create enough pull. If this is the case, do the following:

1. Remove the clear suction tube from the bottom valve fitting and fill completely with water.
2. While the pump is running, attach the tube (filled with water) to the bottom valve fitting.
3. When the fluid enters the pumphead, place the foot valve in the solution tank.
4. Be sure the footvalve/strainer is attached to the suction tubing and is installed in a vertical position.

5.3 Measuring the Pump's Output - Volumetric Test.

This volumetric test will take into account individual installation factors such as line pressure, fluid viscosity, suction lift, etc. This test is the most accurate for measuring the injector's output in an individual installation.

1. Be sure the Injection Fitting and Footvalve/Strainer is clean and working properly.
2. With the injector installed under normal operating conditions, place the Footvalve/Strainer in a large graduated cylinder.
3. Fill the graduated cylinder with the solution to be injected and run the injector until all air is removed from the suction line and the solution enters the discharge tubing.
4. Refill the graduated cylinder, if necessary, and with the Footvalve completely submerged in the solution, note the amount of solution in the graduated cylinder.
5. Run the injector for a measured amount of time and note the amount of fluid injected. A longer testing time will produce more accurate results.

6.0 How to Maintain the Pump

CAUTION: PROPER EYE AND SKIN PROTECTION MUST BE WORN WHEN INSTALLING AND SERVICING THE METERING PUMP

6.1 Routine Inspection and Maintenance

The Pump requires very little maintenance. However, the pump and all accessories should be checked regularly. This is especially important when pumping chemicals. Inspect all components for signs of leaking, swelling, cracking, discoloration or corrosion. Replace worn or damaged components immediately.

Cracking, crazing, discoloration and the like during the first week of operation are signs of severe chemical attack. If this occurs, immediately remove the chemical from the pump. Determine which parts are being attacked and replace them with parts that have been manufactured using more suitable materials. The manufacturer does not assume responsibility for damage to the pump that has been caused by chemical attack.

6.2 How to Clean the Pump

The Pump will require occasional cleaning, especially the Injection fitting, the Footvalve/Strainer, and the pump head valves. The frequency will depend on the type and severity of service

When changing the diaphragm, the pump head chamber and pump head cover should be wiped free of any dirt and debris.

Periodically clean the injection/check valve assembly, especially when injecting fluids that calcify such as sodium hypochlorite. These lime deposits and other build ups can clog the fitting, increase the back pressure and interfere with the check valve operation.

Periodically clean the suction strainer.

Periodically inspect the air vents located on the back of the motor compartment and under the pump head. Clean if necessary.

Exploded View

C-600HV

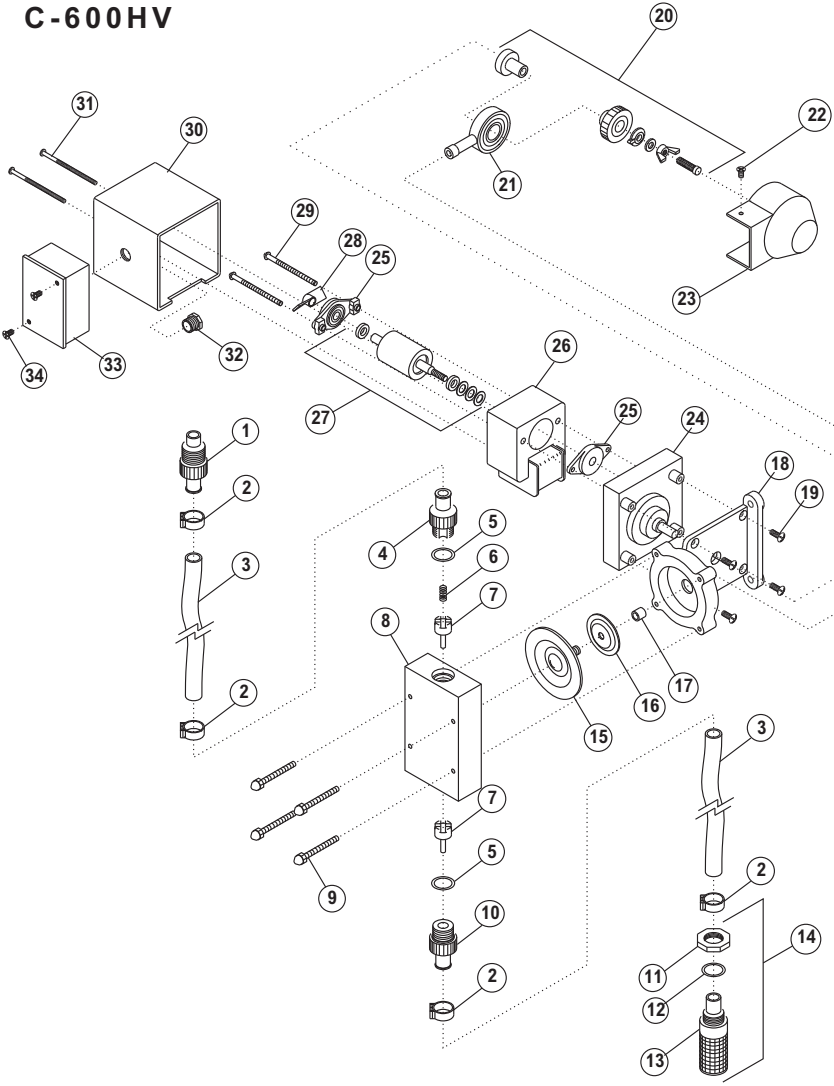

C-600HV Parts List

	<u>Catalog No.</u>	<u>Description</u>	<u>Amount Reqd.</u>
1.	C-3391-10	Injection Fitting	1
2.	C-3330	Clamp	4
3.	C-334-10	Tubing 5/8" O.D. , 5FT	2
	4.C-428-10	Top Adaptor, 5/8" Tube	1
5.	90003-033	O-ring (EP) (Viton)	1
6.	C-354-2	Spring	1
7.	C-926E	Check Valve (Hypalon)	1
	C-926V	Check Valve (Viton)	1
8.	C-3203	Headblock (Clear) (Polyethylene)	1
9.	C-3504	Screw, (Headblock) #8-32X1 1/2	4
10.	C427-10	Bottom Adaptor, 5/8" Tube	1
11.	C-3345C	Lock Nut	1
12.	C-3345C	O-ring	1
13.	C-3373-10	Foot Strainer	1
14.	C-3393-10	Combination Foot Strainer Bulkhead	1
15.	C-3106NH	Diaphragm (Hypalon)	1
	C-3106NV	Diaphragm (Viton)	1
16.	90006-526	Aluminum Backup Washer	1
17.	76000-514	H.V. Aluminum Spacer	1
18.	C-3301	Motor Mount	2
19.	C-624	Screw 10-32X1/2	4
20.	C-3325	Cam Set	1
21.	C-3304	Yoke and Bearing	1
22.	90011-155	Screw 6-32X3/8"	1
23.	90002-201	Cam Cover	1
24.	C-618P-60	Gearbox Assembly(60 RPM)	1
	C-618P-125	Gearbox Assembly(125 RPM)	1
	C-618P-250	Gearbox Assembly(250 RPM)	1
25.	C-612PB	Armature Bearing	2
26.	C-615P1	Motor Winding (115V-60hz)	1
	C-615P2	Motor Winding (230V-60hz)	1
	C-615P3	Motor Winding (220V-50hz)	1
27.	70000-027	Rotor w/ Spacers	1
28.	C-612F	Armature Fan	1
29.	C-625	Motor Screw 8-32X2 3/4	2
30.	C-608P	Motor Cover (Zinc)	1
	C-608P(AL)	Motor Cover (Aluminum)	1
31.	C-628	Cover Screw 6-32 X 2 3/4	2
32.	90007-515	1/2" Aluminum Chase Nipple	1
33.	C-308J	Junction Box	1
34.	90011-129	Junction Box screw 8-32 X 5/16	2

Exploded View

C-600P

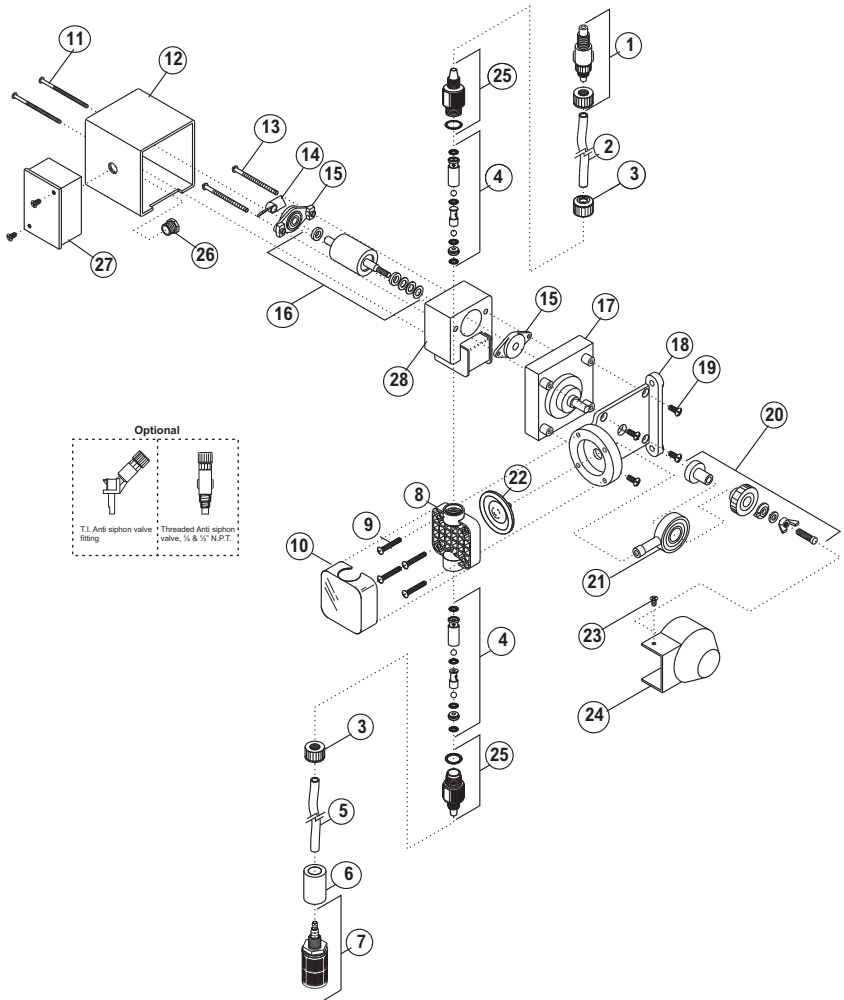

C- 600P Parts List

Catalog No.	Description	Amount Req'd.
1. C-395-6V	Injection valve 6 PSI, Viton	1
C-395-6E	Injection valve 6 PSI, EP (optional)	1
2. C-335-6	Discharge Tubing 3/8 OD, 5ft. Opaque Poly-E	1
3. C-330-6	Tube Nut	2
4. K-568V-4	Bullet valve (double ball), Viton, 4 pack set	2
K-568V-10	bullet valve (double ball), Viton, 10 pack set	2
K-569E-4	Bullet valve (double ball), EP, 4 pack set (optional)	2
K-569E-10	Bullet valve (double ball), EP, 10pack set(optional)	2
5. C-334-6	Suction tubing 3/8' OD, 5ft. Clear PVC w/ indicator	1
6. C-346	Ceramic weight	1
7. C-345V	Foot valve / strainer Poly-Pro, Viton	1
C-345E	Foot valve / strainer Poly Pro, EP (optional)	1
8. C-535	Heavy duty molded pump head	1
9. C-504HD	Screw, HD Pump head 10-32 x 1-1/4'	4
10. C-535FC	Pump head cover, Chem feed logo	1
11. C-628	Cover screw 6-32 x 2-3/4' Steel	2
12. C-608P	Motor Cover	1
13. C-625	Motor screw 8-32 x 2-1/2'	2
14. C-612F	Rotor Fan	1
15. C-612PB	Rotor Bearing	2
16. C-616PN	Rotor w/ Spacer	1
17. C-618P-14	Gearbox Assembly, 14 RPM	1
C-618P-30	Gearbox Assembly, 30 RPM	1
C-618P-45	Gearbox Assembly, 45 RPM	1
C-618P-60	Gearbox Assembly, 60 RPM	1
C-618P-125	Gearbox Assembly, 125 RPM	1
C-618P-250	Gearbox Assembly, 250 RPM	1
18. C-301	Motor Mount	1
19. C-624	Motor Mount Screw 10-32 x 1/2'	4
20. C-325	Cam S/A C-600	1
21. C-304	Yoke w/Bearings	1
22. C-406T	Diaphragm Teflon coated, EP	1
23. 90011-155	Screw 6-332 x 3/8'	1
24. 90002-201	Cam Cover	1
25. C-550-6V	Bullet Valve Adapter, Viton O-ring	2
C-560-6E	Bullet Valve Adapter, EP O-ring	2
26. 90007-515	1/2" Aluminum Chase Nipple	1
27. C-308J	Junction Box Complete w/Cover and Gasket	1
28. C-615P-1	Stator S/A 115V/60Hz, blue-black (lead wires)	1
C-615P-2	Stator S/A 230V/60Hz, red-black (lead wires)	1
C-615P-3	Stator S/A 220V/50Hz, brown-blue (lead wires)	1
C-615P-4	Stator S/A 24V/60Hz, blue-white (lead wires)	1
C-615P-6	Stator S/A 230V/60Hz, red-yellow (lead wires)	1
C-615P-8	Stator S/A 220V/50Hz, brown-yellow (lead wires)	1
C-615P-9	Stator S/A 115V/60Hz, blue-yellow (lead wires)	1

LIMITED WARRANTY

Your new pump is a quality product and is warranted to be free of defects as set down in this policy. All parts, including rubberized goods, and labor are covered under warranty for 90 days from the date of purchase. Used peristaltic pump tube assemblies are not warranted. Parts, excluding rubberized goods, are covered under warranty for 12 months from the date of purchase.

Warranty coverage does not include damage to the pump that results from misuse, carelessness, abuse or alteration. Only the repair or the replacement of the pump is covered. Blue-White Industries does not assume responsibility for any other loss or damage.

Warranty status is determined by the pump's serial label and the sales invoice or receipt. The serial label must be on the pump and the pump must be accompanied by the sales invoice or receipt to obtain warranty coverage. The warranty status of the pump will be verified by Blue-White or a factory authorized service center.

Please be advised; injection and metering devices are not intended as a means of treating water to render it suitable for human consumption. When used as hypochlorinators, they are meant to destroy bacteria and algae contamination, before it's removal by filtration. Acid and soda injectors are used for PH control (balance). Blue-White injectors are factory tested with water only for pressure and performance. **Installers and operators of these devices must be well informed and aware of the precautions to be taken when injecting various chemicals -especially those considered hazardous or dangerous.**

Should it become necessary to return an injector for repair or service, you must attach information regarding the chemical used as some residue may be present within the unit which could be a hazard to service personnel.

Blue-White Industries will not be liable for any damage that may result by the use of chemicals with their injectors and it's components. Thank you.

PROCEDURE FOR IN WARRANTY REPAIR

Carefully pack the pump to be repaired, include the foot strainer and injection/check valve fitting. Enclose a brief description of the problem as well as the original invoice or sales receipt showing the date of purchase. The receipt will be returned with the unit. Prepay all shipping costs. COD shipments will not be accepted. Warranty service must be performed by the factory or an authorized service center. Damage caused by improper packaging is the responsibility of the sender.

AUTHORIZED SERVICE CENTERS

ARKANSAS

BT Environmental, Inc
Bill Thomason
225 Castleberry Street
Hot Springs, AR 71901
501-624-3837

CALIFORNIA (NORTHERN)
Howard E. Hutching company
(Repair Center)
7190 Penryn Plaza
Penryn, CA 95663
800-568-3958

Swimco Electric Co.
753 Camden Avenue
Campbell, CA 95008
408-378-2607

CALIFORNIA (SOUTHERN)
Blue-White Industries
(Repair Center)
5300 Business Drive
Huntington Bch. CA 92649
714-893-8529

COLORADO
Denver Winpump
5754 Lamer ave
Arvada, CO 80002
303-424-3551

CONNECTICUT
Cronin-Cook & Associates
24 West Road
Vernon, CT 06029
860-875-0544

Rice Pump & Motor Repair
5740 Powerline Road
Ft. Lauderdale FL 33309
954-776-6049

American Pump
7580-A W. Tennessee St.
Tallahassee, FL 32304
850-575-9618

Jerry Lee Chemical Co.
3407 W. Old Fairfield Drive
Pensacola, FL 32505
904-432-9929

Picard Chemical

1670 S. Congress Avenue
W. Palm Beach, FL 33406
561-965-3434

ILLINOIS
Mullarkey Associates
(Repair Center)
12346 S. Keeler Ave.
Alsip, IL 60658
708-597-5558

MARYLAND
Century Pool Service, Inc
5020 Nicholson Court, #201
Kensington, MD 20895
301-231-8999

NEW YORK
Sherwood Specialties, Inc.
875 Atlantic Ave. 'B'
Rochester, NY 14609
585-546-1211

NORTH CAROLINA
Southern Industrial Sales
1903 Herring Avenue
Wilson, NC 27893
800-872-7665

SOUTH DAKOTA
Son-Aqua Distributing
Jim Robinson
2447 W. Main Street
Rapid City, SD 57702
605-343-7716

TENNESSEE
Rock City Machine
307 3rd Avenue South
Nashville, TN 37201
615-244-1371

TEXAS
Alamo Water Refiners
13700 Hwy. 90 West
San Antonio, TX 78245
210-677-8400

Shelter's Water Refining
Robert Shelton
2708 E. Randol Mill Rd.
Arlington, TX 76011
817-640-6188



Users of electrical and electronic equipment (EEE) with the WEEE marking per Annex IV of the WEEE Directive must not dispose of end of life EEE as unsorted municipal waste, but use the collection framework available to them for the return, recycle, recovery of WEEE and minimize any potential effects of EEE on the environment and human health due to the presence of hazardous substances. The WEEE marking applies only to countries within the European Union (EU) and Norway. Appliances are labeled in accordance with European Directive 2002/96/EC.

Contact your local waste recovery agency for a *Designated Collection Facility* in your area.