

# Blue-White<sup>®</sup>

Industries, Ltd.

## Pitot Tube Insertion Meters

Engineering and Technical Data

### F-300 U-300 D-300

**Clamp-on Insertion Mount**  
**Dual GPM / LPM scale**

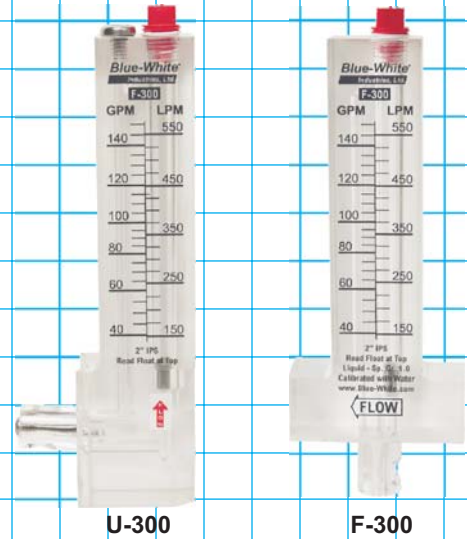

### Features:

- Dual GPM/LPM scale printed on both sides of the meter.
- 1" through 8" pipe sizes.
- Flow rates from 2 to 1900 GPM (8 to 7200 LPM).
- Corrosion resistant 316SS or Teflon internal float materials.
- One piece machined acrylic body.
- Mounts to existing pipe. No unions or adapters required.
- Models for mounting on horizontal or vertical pipe.
- Mounting clamps and gasket included.

### Specifications:

**Pipe Requirements:** ..... IPS inch pipe size (ASTM-D-1785)  
**Max. Psi (bar):** ..... 150 PSI (10.3 bar) @ 70° F (21° C)  
**Max. fluid temp.:** ..... 190° F (88° C) @ 0 PSI  
**Max. ambient temp.:** ..... 14° to 110° F / -10° to 43° C  
*Note: Temperature & Pressure ratings of meter only. Actual pipe rating may vary.*

**Full scale accuracy:** ..... +/- 10%  
**Power requirement:** ..... No power required  
**Enclosure:** ..... NEMA 4X (IP56)  
**Approximate shipping wt:** ... 1"-4" units: 1 lb. (.45 kg)  
 6"-8" units: 2 lb. (.91 kg)

### Materials of Construction:

**Meter Body:** ..... Cast Acrylic  
**Float:** ..... Standard range models = 316SS  
 Low range models = Teflon  
**Gasket:** ..... Neoprene  
**Pipe Clamp:** ..... 300 series Stainless Steel  
**Pitot screw:** ..... 1" thru 2" models only. 300 series stainless Steel

### Installation Requirements:

#### Minimum Straight Pipe Length Requirements

The meter's accuracy is affected by disturbances such as pumps, elbows, tees, valves, etc., in the flow stream. Install the meter in a straight run of pipe **as far as possible** from any disturbances. The distance required for accuracy is 10 times the nominal pipe diameter before the meter and 4 times the nominal pipe diameter after the meter.

#### Example of Minimum Straight Pipe Length Requirements

Nominal Pipe Diameter	Minimum Inlet Pipe Length	Minimum Outlet Pipe Length
3 inch	30 inch (10 X 3")	12 inch (4 X 3")
1-1/2 inch	15 inch (10 x 1.5")	6 inch (4 x 1.5")
6 inch	60 inch (10 x 6")	24 inch (4 x 6")

#### Mounting location

- The meter is designed to withstand outdoor conditions.
- F series meters must be mounted at the vertical (twelve o'clock) position on horizontal pipe only.
- U & D series meters must be mounted on vertical pipe only.
- The pipe must be completely full of water at all times.
- See the minimum straight length of pipe requirement chart above.
- The meter can accurately measure flow from one direction only.
- U-series meters measure upward flows only.
- D-series meters measure downward flows only.

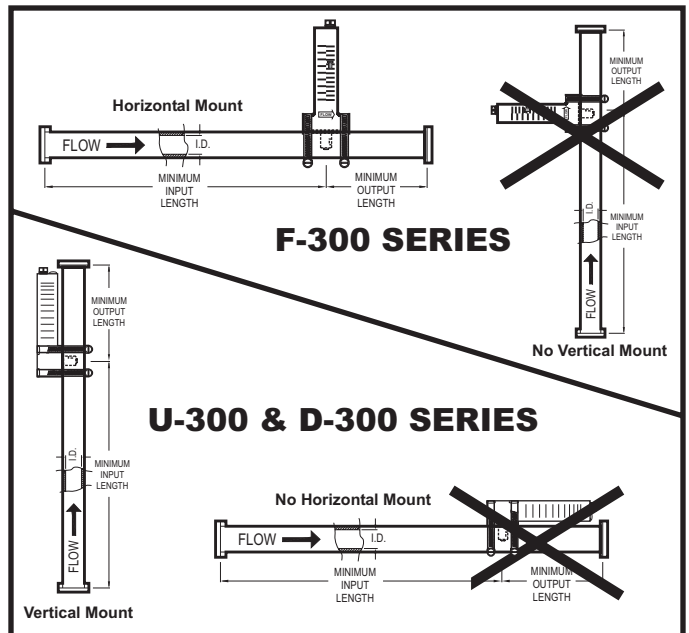

# Blue-White<sup>®</sup> Industries, Ltd.

## Pitot Tube Insertion Meters

### Dimensions:

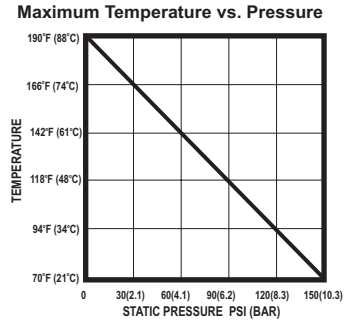
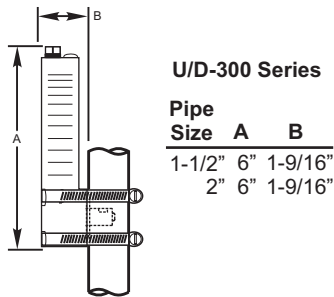
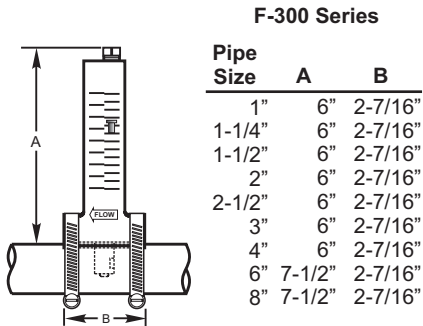

### Flow Stream Requirements:

Low viscosity fluids with a specific gravity of 1.0.

### Model Number Matrix:

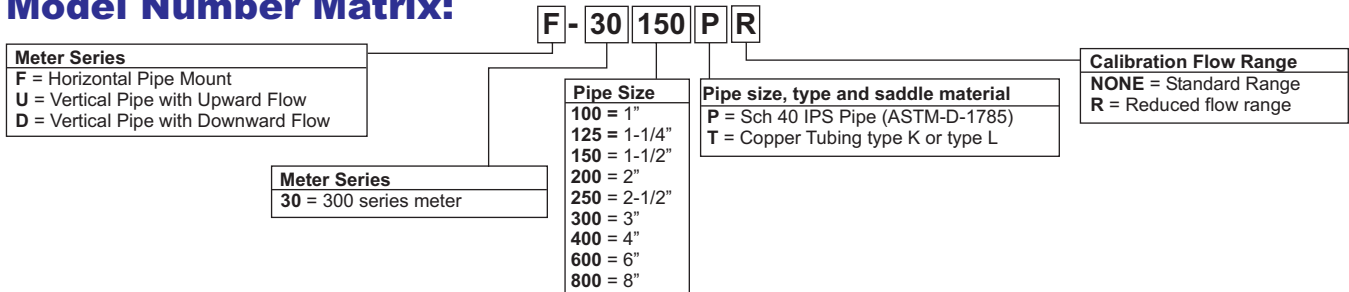

### Pipe Size, Flow Range and Display Model Options:

#### Models for Mounting on Horizontal Pipe

##### Models for U.S. IPS Sch40 Pipe (ASTM 1785)

Display in U.S. Gallons and Liters per Minute

Pipe Size	GPM Flow Range	LPM Flow Range	Model Number
1"	5 to 35	20 to 160	F-30100P
1"	2 to 10	8 to 38	F-30100PR
1-1/4"	15 to 75	60 to 280	F-30125P
1-1/4"	5 to 35	30 to 130	F-30125PR
1-1/2"	20 to 100	75 to 375	F-30150P
1-1/2"	9 to 30	30 to 110	F-30150PR
2"	40 to 150	150 to 550	F-30200P
2"	15 to 70	60 to 260	F-30200PR
2-1/2"	60 to 240	225 to 900	F-30250P
3"	80 to 300	300 to 1125	F-30300P
3"	40 to 140	160 to 520	F-30300PR
4"	125 to 500	550 to 2000	F-30400P
6"	250 to 1050	900 to 3900	F-30600P
8"	500 to 1900	2000 to 7200	F-30800P

##### Models for Copper Tubing types K & L

Display in U.S. Gallons and Liters per Minute

Pipe Size	GPM Flow Range	LPM Flow Range	Model Number
1"	5 to 35	20 to 160	F-30100T
1"	2 to 10	8 to 38	F-30100TR
1-1/4"	15 to 75	60 to 280	F-30125T
1-1/4"	5 to 35	30 to 130	F-30125TR
1-1/2"	20 to 100	75 to 375	F-30150T
1-1/2"	9 to 30	30 to 110	F-30150TR
2"	40 to 150	150 to 550	F-30200T
2"	15 to 70	60 to 260	F-30200TR
2-1/2"	60 to 240	225 to 900	F-30250T
3"	80 to 300	300 to 1125	F-30300T
3"	40 to 140	160 to 520	F-30300TR
4"	125 to 500	550 to 2000	F-30400T
6"	250 to 1050	900 to 3900	F-30600T
8"	500 to 1900	2000 to 7200	F-30800T

#### Models for Mounting on Vertical Pipe

##### Models for U.S. IPS Sch40 Pipe (ASTM 1785)

Display in U.S. Gallons and Liters per Minute

Pipe Size	GPM Flow Range	LPM Flow Range	Flow Direction	Model Number
1-1/2"	20 to 100	75 to 375	UP	U-30150P
1-1/2"	20 to 100	75 to 375	DOWN	D-30150P
1-1/2"	9 to 30	30 to 120	UP	U-30150PR
1-1/2"	9 to 30	30 to 120	DOWN	D-30150PR
2"	40 to 150	150 to 550	UP	U-30200P
2"	40 to 150	150 to 550	DOWN	D-30200P
2"	18 to 70	70 to 280	UP	U-30200PR
2"	18 to 70	70 to 280	DOWN	D-30200PR

##### Models for Copper Tubing types K & L

Display in U.S. Gallons and Liters per Minute

Pipe Size	GPM Flow Range	LPM Flow Range	Flow Direction	Model Number
1-1/2"	20 to 100	75 to 375	UP	U-30150T
1-1/2"	20 to 100	75 to 375	DOWN	D-30150T
1-1/2"	9 to 30	30 to 120	UP	U-30150TR
1-1/2"	9 to 30	30 to 120	DOWN	D-30150TR
2"	40 to 150	150 to 550	UP	U-30200T
2"	40 to 150	150 to 550	DOWN	D-30200T
2"	18 to 70	70 to 280	UP	U-30200TR
2"	18 to 70	70 to 280	DOWN	D-30200TR