

Blue-White[®]

Industries, Ltd.

Variable Area Flow Meters

Engineering and Technical Data

F-462N

- 2" and 63mm Pipe Size**
- F/NPT, Socket Fusion and Butt Fusion connections**
- Rib Guided Float**
- No Metal in the fluid path**
- Shield option**

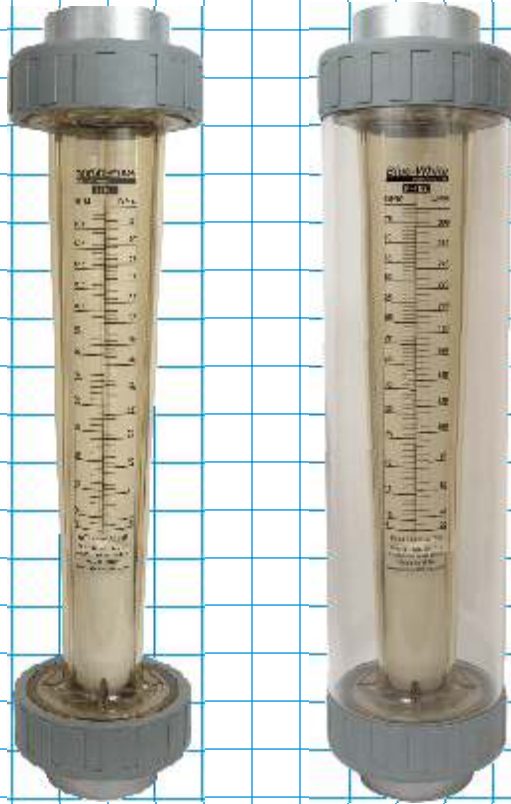

Features:

- Polysulfone meter body resists high temperatures and pressures.
- Teflon float and optional Polysulfone, Polypropylene or PVDF adapters for corrosive applications.
- Rib guided float.
- No metal in the fluid path.
- Direct reading permanent scale.
- Optional polycarbonate splash shield.

Materials of Construction:

- Meter Body: Polysulfone
- Adapters: Polysulfone
(optional Polypropylene & PVDF)
- O-ring seals: Viton[®] (optional EP)
- Union Nuts: Reinforced Nylon
- Float: Teflon
- Float Stop: Polysulfone
- Optional Shield: Polycarbonate

Specifications:

- Max. working pressure: 150 PSI (10.3 bar) @ 70° F (21° C)
- Max. fluid temperature: 200° F (93° C) @ 0 PSI
- Full scale accuracy: +/- 2.5%
- Calibration fluid: water, specific gravity 1.0
- Scale length: 8" (200mm)
- Environment: Not for direct sunlight exposure.
- Maximum pressure drop: 2 PSI
- Approximate shipping wt: ... 5 lb. (2.27 kg)

Dimensions:

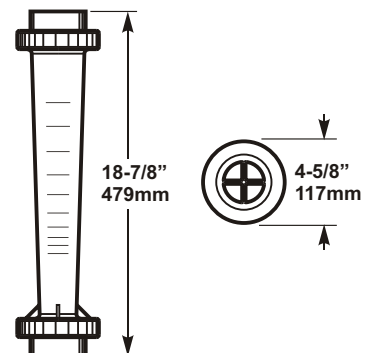

Maximum Temperature vs. Pressure

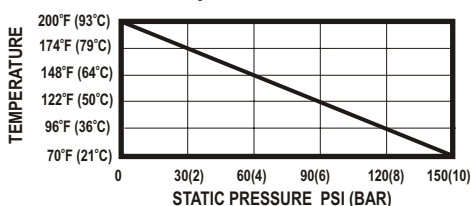

Blue-White[®]

Industries, Ltd.

Variable Area Flow Meters

Installation Requirements:

1. Misalignment will damage the meter!

Flowmeter must be installed in an exact vertical plane to ensure accuracy. Be certain of proper plumbing alignments. Misalignment may cause the o-ring seals to leak. The meterbody material can be damaged by UV rays. **Do not install in direct sunlight.**

2. Pipe dope and glue will damage the meter!

Use only Teflon[®] tape on the threaded adapters. The meter body and plastic fittings cannot tolerate PVC Glue and/or pipe dope. Even fumes can cause severe damage. If you are installing your flowmeter to a glued pipe configuration, install the flowmeter *after* all glued fittings are dried and lines are purged of all fumes. **Never** hold the meter body with pliers or like tools. Union nuts should be hand tightened only. **DO NOT OVER-TIGHTEN!**

3. Vibration and heavy loads will damage the meter!

Wall, floor and ceiling mounts and supports must be carefully aligned with the meter body and sturdy enough to support the plumbing and prevent vibration. Never allow the flowmeter to support the weight of related piping.

4. Solenoid valves will damage the meter!

Avoid a system that will impose a sudden burst of flow to the meter. Such a burst will cause the float to impact the float stop with destructive force. Solenoid valves, or other quick opening valves cannot be used unless meter is protected against sudden bursts of flow.

5. High pressures and temperatures will damage the meter!

The maximum acceptable temperature and pressure is interdependent. The maximum acceptable working pressure is dependant on the actual fluid temperature. The maximum acceptable fluid temperature is dependant on the actual working pressure. (see Temperature Vs. Pressure chart).

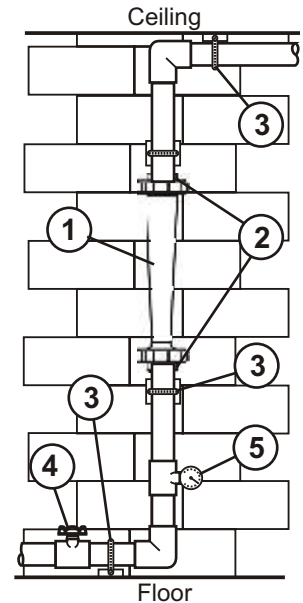

Flow Range and Model Options:

Models with F/NPT connections

- Models for Liquid

MODEL NUMBER	Dual Scale Range GPM	Range LPM	Adapter F/NPT	Float Material	Adapter Material
F-462200LX-32H	2 to 20	8 to 80	2"	Teflon	Polysulfone
F-462500LX-32H	5 to 50	20 to 200	2"	Teflon	Polysulfone
F-462800LX-32H	8 to 80	30 to 300	2"	Teflon	Polysulfone

Models with Butt Fusion connections

- Models for Liquid

MODEL NUMBER	Dual Scale Range GPM	Range LPM	Adapter B.F.	Float Material	Adapter Material
F-462200LX-34G	2 to 20	8 to 80	63mm	Teflon	Polypropylene
F-462500LX-34G	5 to 50	20 to 200	63mm	Teflon	Polypropylene
F-462800LX-34G	8 to 80	30 to 300	63mm	Teflon	Polypropylene
F-462200LX-34K	2 to 20	8 to 80	63mm	Teflon	PVDF
F-462500LX-34K	5 to 50	20 to 200	63mm	Teflon	PVDF
F-462800LX-34K	8 to 80	30 to 300	63mm	Teflon	PVDF

Models with Socket Fusion connections

- Models for Liquid

MODEL NUMBER	Dual Scale Range GPM	Range LPM	Adapter S.F.	Float Material	Adapter Material
F-462200LX-33G	2 to 20	8 to 80	2"	Teflon	Polypropylene
F-462500LX-33G	5 to 50	20 to 200	2"	Teflon	Polypropylene
F-462800LX-33G	8 to 80	30 to 300	2"	Teflon	Polypropylene
F-462200LX-33K	2 to 20	8 to 80	2"	Teflon	PVDF
F-462500LX-33K	5 to 50	20 to 200	2"	Teflon	PVDF
F-462800LX-33K	8 to 80	30 to 300	2"	Teflon	PVDF

Models with F/NPT connections

- Models for Liquid with splash shield

MODEL NUMBER	Dual Scale Range GPM	Range LPM	Adapter F/NPT	Float Material	Adapter Material
F-462200LX-32HC	2 to 20	8 to 80	2"	Teflon	Polysulfone
F-462500LX-32HC	5 to 50	20 to 200	2"	Teflon	Polysulfone
F-462800LX-32HC	8 to 80	30 to 300	2"	Teflon	Polysulfone

Models with Butt Fusion connections

- Models for Liquid with splash shield

MODEL NUMBER	Dual Scale Range GPM	Range LPM	Adapter B.F.	Float Material	Adapter Material
F-462200LX-34GC	2 to 20	8 to 80	63mm	Teflon	Polypropylene
F-462500LX-34GC	5 to 50	20 to 200	63mm	Teflon	Polypropylene
F-462800LX-34GC	8 to 80	30 to 300	63mm	Teflon	Polypropylene
F-462200LX-34KC	2 to 20	8 to 80	63mm	Teflon	PVDF
F-462500LX-34KC	5 to 50	20 to 200	63mm	Teflon	PVDF
F-462800LX-34KC	8 to 80	30 to 300	63mm	Teflon	PVDF

Models with Socket Fusion connections

- Models for Liquid with splash shield

MODEL NUMBER	Dual Scale Range GPM	Range LPM	Adapter S.F.	Float Material	Adapter Material
F-462200LX-33GC	2 to 20	8 to 80	2"	Teflon	Polypropylene
F-462500LX-33GC	5 to 50	20 to 200	2"	Teflon	Polypropylene
F-462800LX-33GC	8 to 80	30 to 300	2"	Teflon	Polypropylene
F-462200LX-33KC	2 to 20	8 to 80	2"	Teflon	PVDF
F-462500LX-33KC	5 to 50	20 to 200	2"	Teflon	PVDF
F-462800LX-33KC	8 to 80	30 to 300	2"	Teflon	PVDF

Correction factor formulas for AIR models

<p>PRESSURE CORRECTION</p> $\sqrt{\frac{14.7 + \text{Working PSIG}}{14.7}}$

<p>TEMPERATURE CORRECTION</p> $\sqrt{\frac{520}{460 + \text{Working Temp } ^\circ\text{F}}}$
--

Notes:

- 1) Liquid models calibrated with water, Sp.Gr. 1.0. Custom Sp.Gr. calibrations available. Contact the factory.
- 2) Air models calibrated at standard Conditions (70°F @ 14.7 PSia). Temperature and pressure correction may be required. Contact the factory for custom calibrations.
- 3) Gallons shown are U.S. Gallons.